

Z1 350Z STEERING WHEEL REPLACEMENT INSTALLATION MANUAL



This Installation Manual is intended for the following models:

2003-2008

Nissan 350Z

PROLOGUE:

Study these instructions completely before proceeding to assembly. The installer must have a thorough knowledge of automotive systems operation. If unfamiliar with any of the concepts outlined in this instruction, we recommend the installation be completed by a qualified professional.

WARNING!

Extreme caution should be taken when performing maintenance or performance upgrades to your vehicle. Please observe and abide by any Warning or Caution labels placed on the various components and tools used when servicing your vehicle. If you have any questions regarding installation or the various components included with the Z1 Motorsports 350Z Steering Wheel Replacement, consult with a Professional Mechanic, or contact Z1 Motorsports for more information.

PARTS INCLUDED:

Item	Quantity	Description
1	1	Steering Wheel

TOOLS REQUIRED:

- Ratchet
- Ratchet Extension(s)
- Assorted Metric Sockets
- TORX Tamper Resistant Bits (T30, T40)
- Pick
- Screwdrivers
- Impact Gun
- Steering Wheel Puller (Recommended)

SAFETY REQUIREMENTS:

- Always wear safety glasses and any necessary protective garments. If using any fluids, chemicals, or solvents, a respirator is recommended.
- Always turn the ignition to the OFF position and disconnect the NEGATIVE battery terminal.
- Always use properly rated jack stands when working under your vehicle.
- Always keep limbs and parts away from moving drivetrain parts.
- Only operate drivetrain in safe space and well-ventilated areas.

BEFORE YOU BEGIN:

Remove contents from the Z1 Motorsports Steering Wheel and verify that ALL necessary hardware is present.

PROCEDURE:

1. Place the transmission in Park position (or in Reverse gear if equipped with a manual transmission). Apply the parking brake.
2. Turn the Steering wheel until the Front Wheels are straight.
3. Open and support the hood of the vehicle.
4. Disconnect the (-) **NEGATIVE** battery terminal.
5. Let the car sit for half an hour, this will allow the power to drain out to prevent the airbag from potentially going off.
6. Remove the (2) two Covers hiding the (2) two bolts securing the Airbag to the Steering Wheel. *Figure 1.*
7. Remove the (2) two bolts securing the Airbag to the Steering Wheel. These need a [TORX Tamper Resistant T30 Bit](#). It is recommended to replace these bolts after removal. *Figure 1.*

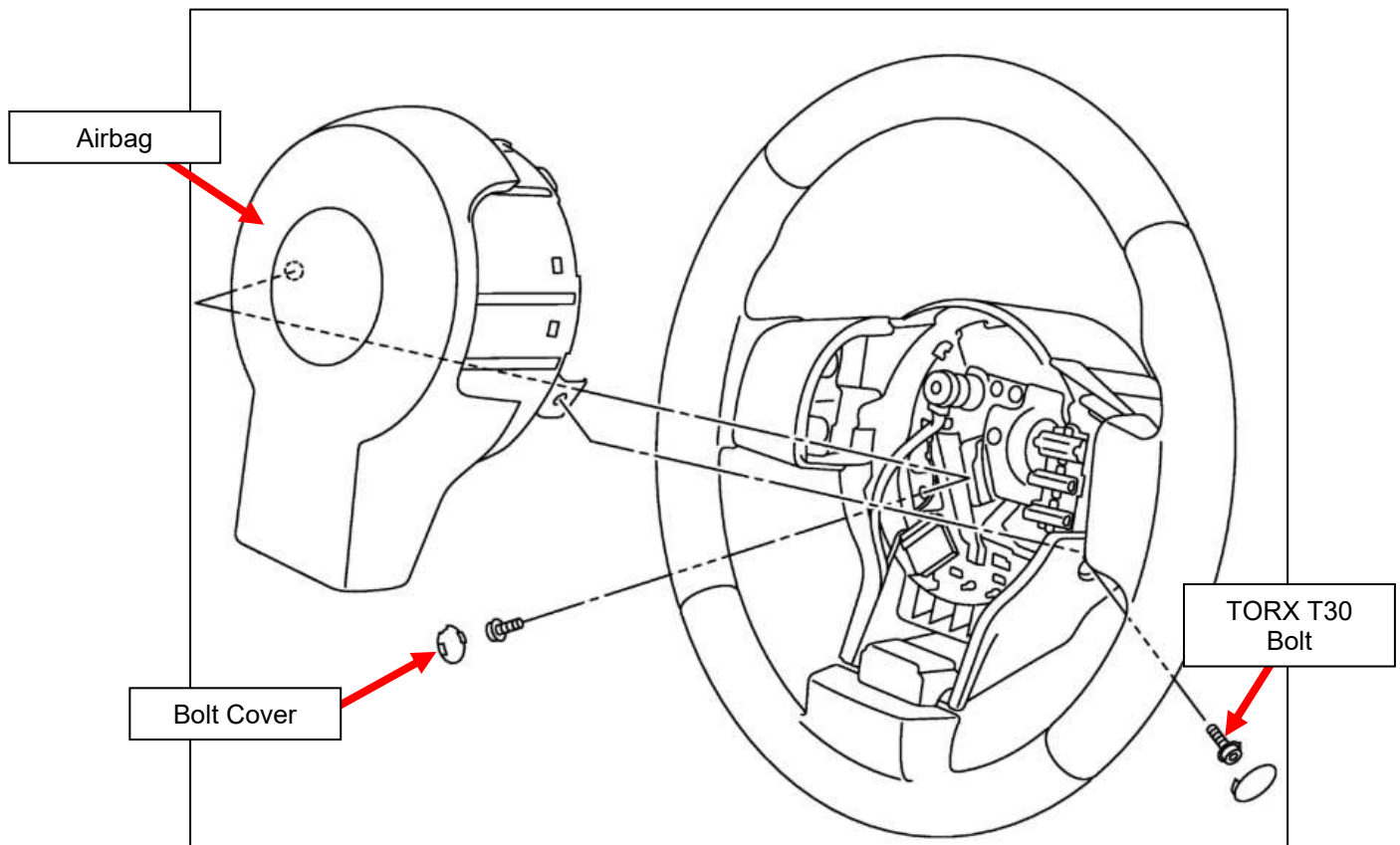

Figure 1

- Remove the Airbag from the Steering Wheel, it is held on by (2) two connectors. Disconnect them and remove the Airbag. *Figure 2.*

NOTE: The connectors have a small clip that must be pushed upwards to remove. *Figure 2.*

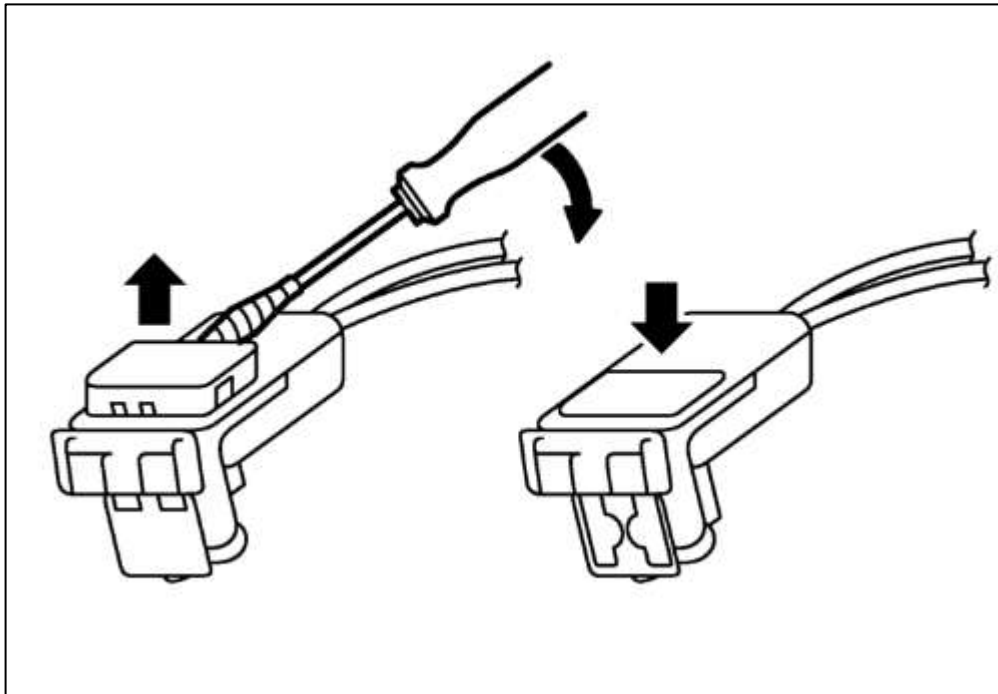

Figure 2

- Disconnect the Horn Connector and the Gray Connector for the Button Controls on the Steering Wheel. *Figure 3.*

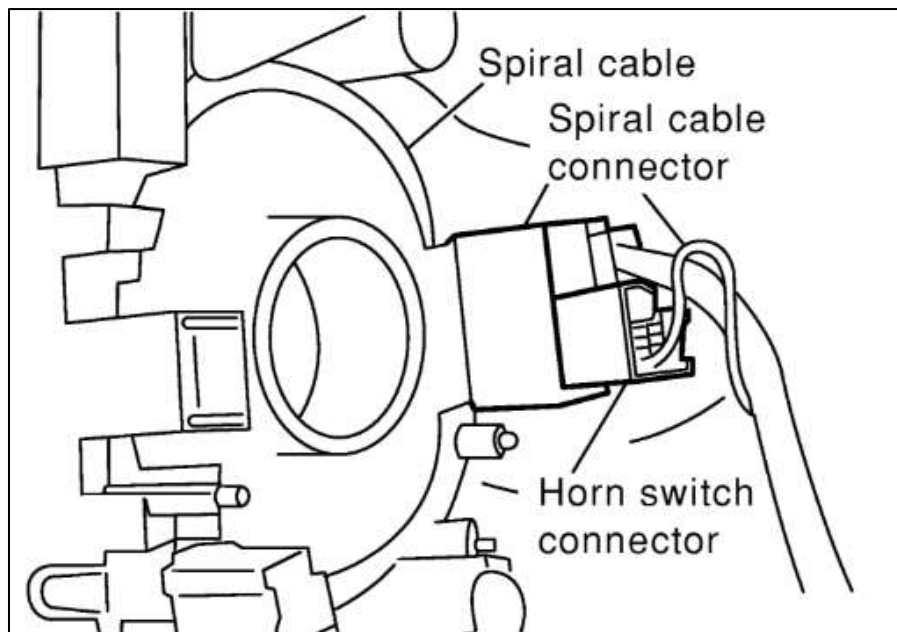

Figure 3

10. Using an Impact Gun, remove the nut in the center of the Steering Wheel. *Figure 4.*

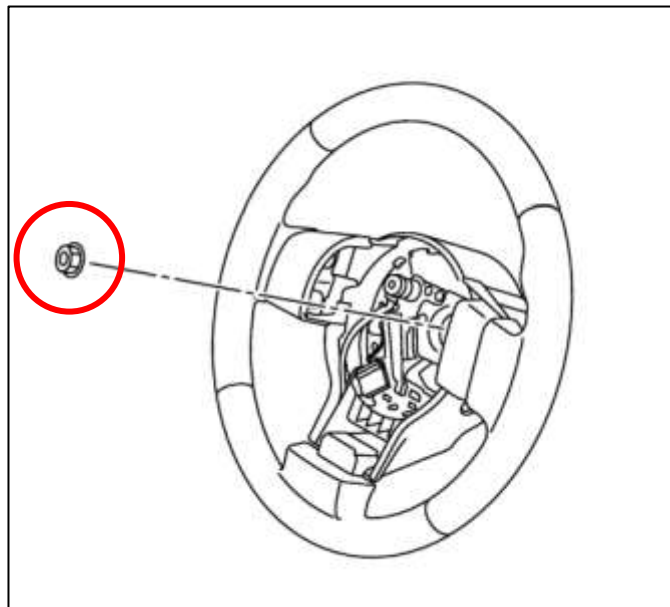

Figure 4

11. Using a Steering Wheel Puller, remove the OE Steering Wheel. If you do not have a Steering Wheel Puller, grab the Steering Wheel at the top and bottom, and rock the wheel back and forth to loosen it. *Figure 5.*

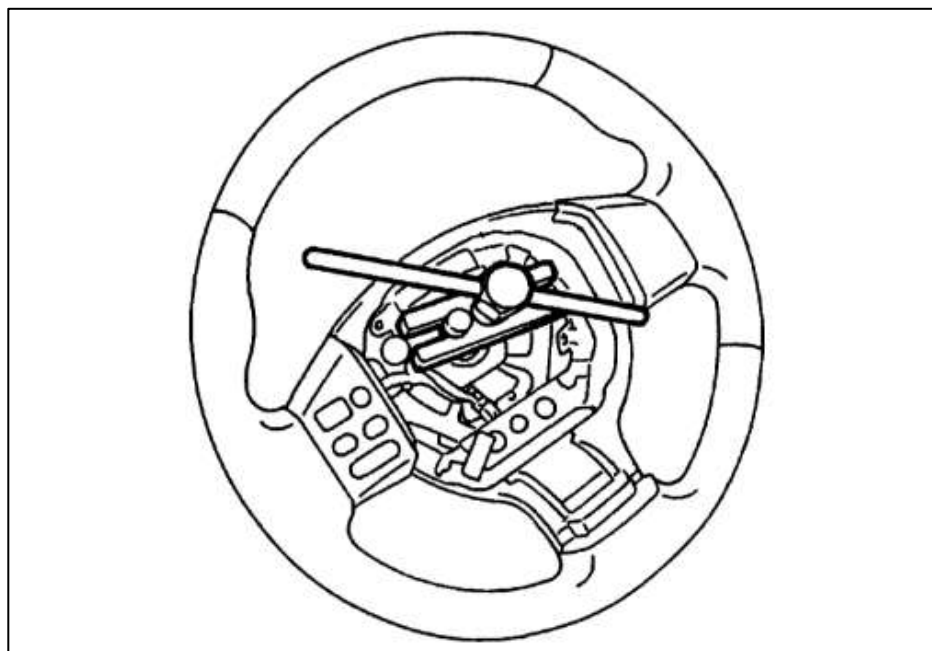

Figure 5

12. With the Steering Wheel removed, use a T40 TORX Bit to remove the (2) two screws securing the Metal Retainer to the Steering Wheel. *Figure 6.*

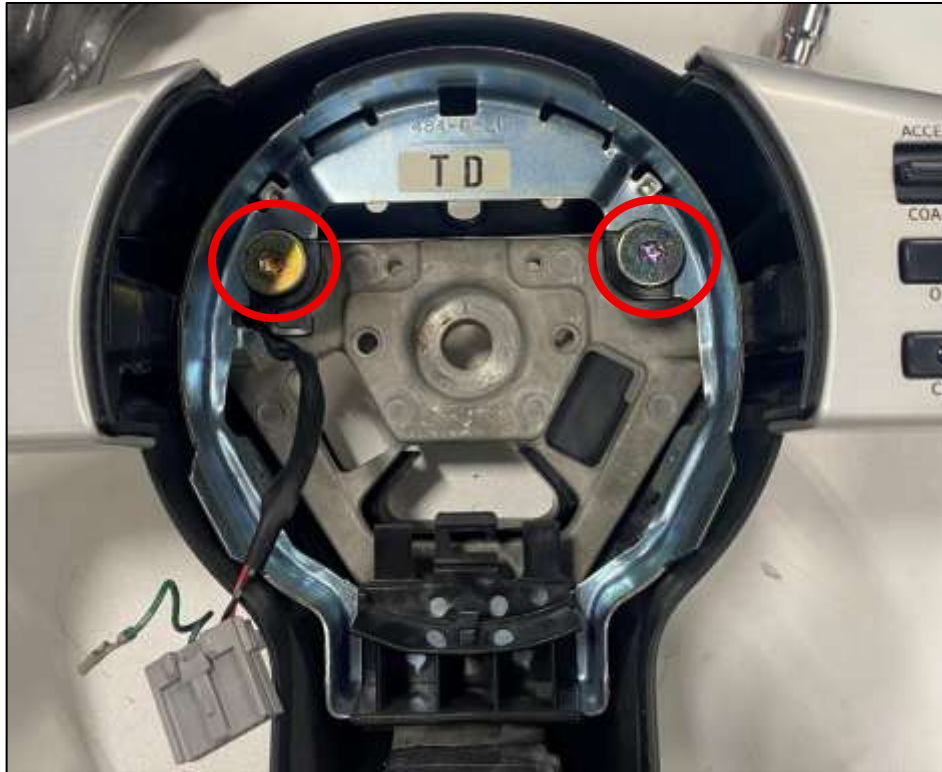

Figure 6

13. Remove the Metal Retainer and the (2) two Springs underneath the Retainer. *Figure 7.*



Figure 7

14. Remove the (1) one screw at the bottom of the Steering Wheel. *Figure 8.*

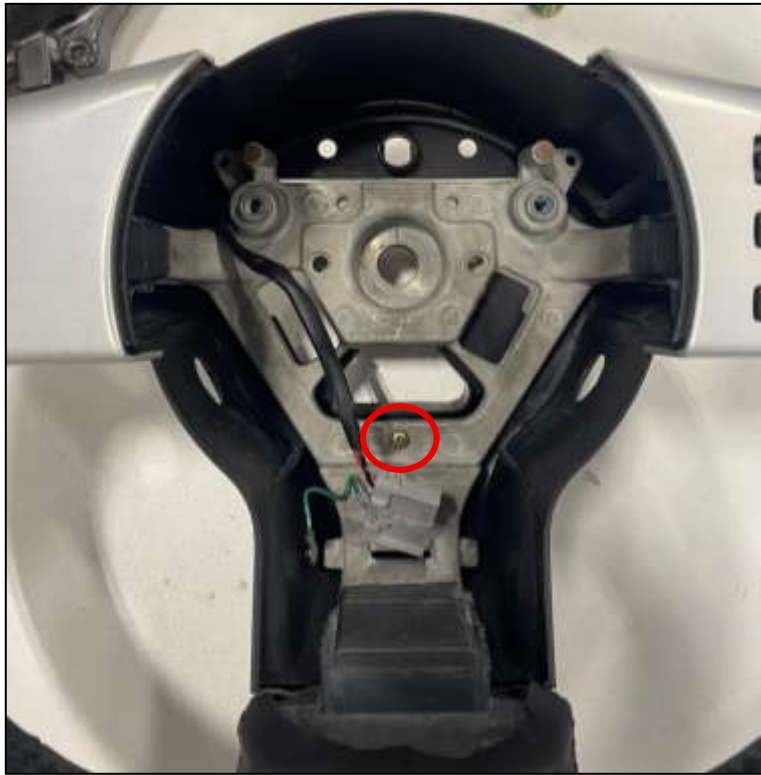

Figure 8

15. Flip the Steering Wheel upside down. Remove the (2) two screws on the back of the wheel to remove the Plastic Trim. *Figure 9.*

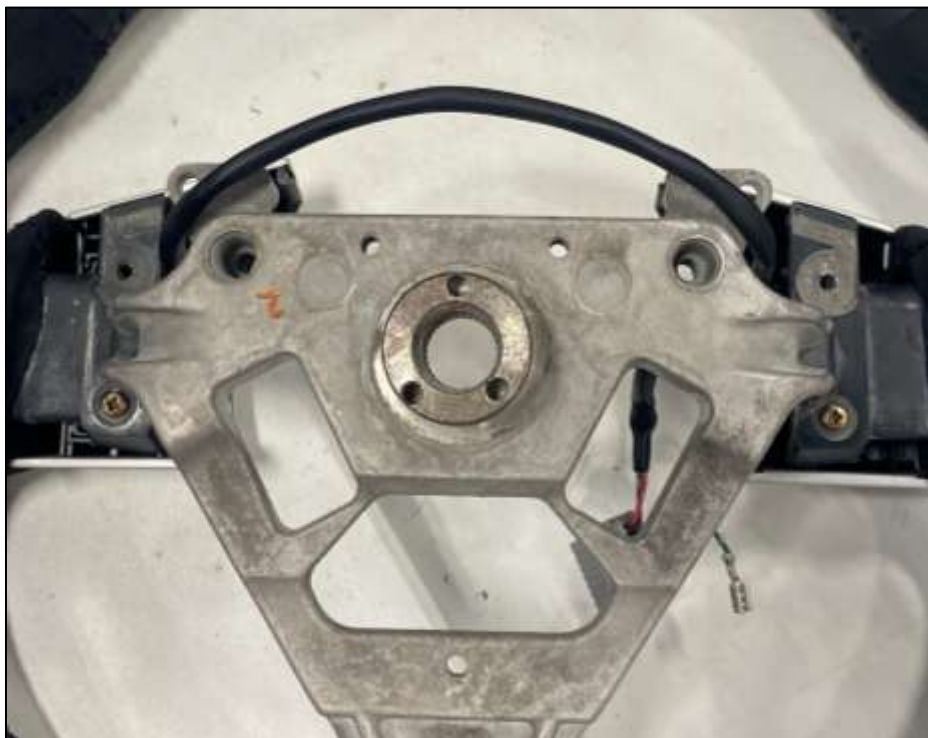

Figure 9

16. Remove the (1) one screw on each side of the Steering Wheel to release the Steering Wheel Controls.
Figure 10.

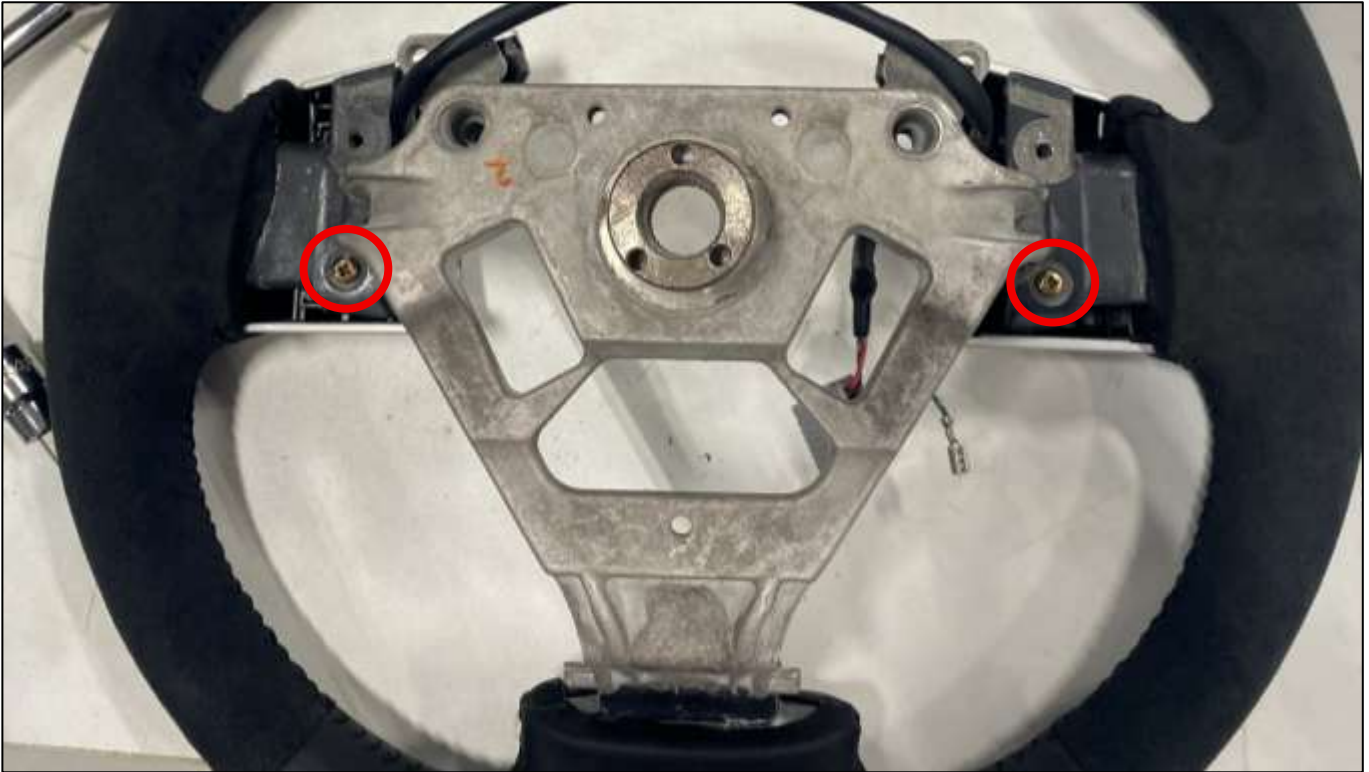

Figure 10

17. Follow *Steps 12-16* in reverse order to reinstall the Trim and Steering Wheel Components to the new Z1 Steering Wheel.
18. Reinstall the Wheel onto the Steering Shaft. Make sure the centering line of the Steering Shaft lines up with the mark of the Steering Wheel.
19. Reinstall the Steering Wheel Nut. Torque to **28 ft-lbs.**
20. Follow *Steps 4-9* in reverse order to reinstall the Airbag.

END

Additional Technical Support:
Contact Z1 Motorsports at info@z1motorsports.com
Or call 770-838-7777 between 9am and 6pm ET